



GREEN DANUBE PORTS

Proposal for a project in the SEE program -
connecting to the European Union
Strategy for the Danube Region

Authors: Alexandru Capatu, Manfred Seitz,
Vienna Economic Forum, 21 November 2011

Motivation



Danube ports are vital elements in the logistics chains and important centres of economic activities

More than sixty potential „green economic knots & best practices for green business“

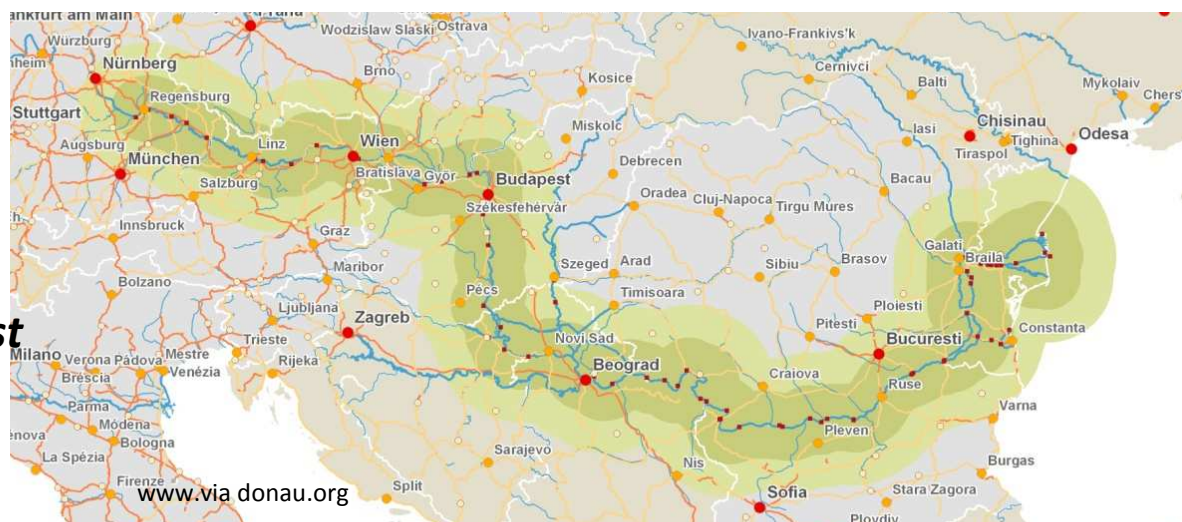

- High potentials for economic development & cross-border regions
- Central hubs for a more efficient and sustainable transport system
- Need to improve eco-footprint

Objectives of the project



- to improve the environmental performance of Danube ports including connected seaports
- to increase their economic productivity with the help of investment into green technologies and by establishment of related new green services

“The project shall be a pilot for a systematic application of green technologies and services in all Danube ports combining environmental protection and economic development”

Methodology



- Eight thematic areas of action
- Implementation strategy & best practices (pilot implementations for key topics)
- Reference solutions for eco-problems & long-term strategies (concrete & affordable)
- Integrated & interdisciplinary approach
- Generation of critical mass of stakeholders
- Incorporating existing experiences (e.g. EcoPorts, WANDA, ENER-Supply, EFFECT, etc.)

Action area – Recovery & cleaning-up



Recycling of unused technical equipment e.g. scrapping of out-of-use cranes, tractors and other port equipment

Proper disposal of pollutants and gain of secondary raw materials for sale



www.portreni.com.ua



www.icpdr.org

pro DANUBE
INTERNATIONAL⁵

Action area – Sediment treatment



Recycling and relocation of polluted sediments

Clean up Underwater ground

Sustainable fairway protection



www.bremenports.de/

Action area – Waste & water treatment



Sustainable waste and water management



A. Paltram, Austria

- ✓ Proper disposal
- ✓ Reduction of resources
- ✓ Cost-effective collection



Action area – Investment into eco-efficiency



Investment into state of the art eco-efficient port equipment and facilities

Examples:

- Electric AC drive technology
- VSG (Variable speed generator) technology
- Hybrid technology with energy storage & recirculation



www.liebherr.com



www.kalmarind.com

- ✓ Reduction of handling operations
- ✓ Improvement of operation efficiency
- ✓ Reduction of emissions

Action area – Emission abatement

Noise & dust & CO2 abatement strategies and actions



Sources of Noise



www.jwdliftech.com

- ✓ Active noise reduction
- ✓ Noise protection systems
- ✓ Dust abatement measures
- ✓ Energy efficiency measures
- ✓ CO2 reduction measures
- ✓ Traffic reduction

Action area – Clean energy (1)



To find for every Danube port the most efficiently form of renewable energy

Wind – Solar – Hydropower-
Biomass Energy
Geothermal Energy - Biofuels



quatrobioworld.com



geograph.org.uk



pro DANUBE
ofrend.com
INTERNATIONAL

Action area – Clean energy (2)

Ports as clean energy producer & distributor



www.magdeburg-hafen.de



Action area – Clean energy (3)

Provision of clean energy to port and terminal operators and port users like barge and vessel operators



www.siemens.com/

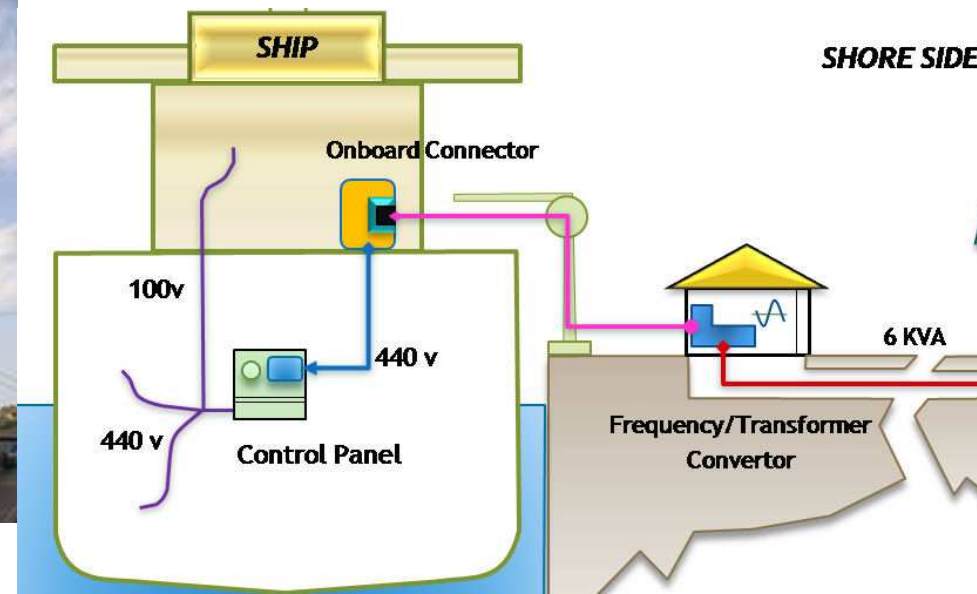

Pawanexh Kohli

Action area – Eco-improvements



Environmental protection and restoration in port areas



- ✓ Preservation of nature
- ✓ Restoration of eco-systems
- ✓ Greening of public space
- ✓ Long-term strategies

Action area – Green business strategy



Integrated environmental management systems

- ✓ Sustainability as part of overall business strategy
- ✓ Annual eco-improvement action plans
- ✓ Effective and sustainable business processes
- ✓ EMAS certification



C EMAS

Expected results (1)



- improve the overall environmental situation in the port areas
- reduce significantly the carbon footprint of port operations
- increase the living-conditions of species living in the port areas
- enhance the productivity of port operations plus the efficiency of business processes
- benefit economically from the implementation of green technologies and the provision of related services
- create new sustainable commercial activities as well as new jobs

Expected results (2)



- GREEN DANUBE PORTS will deliver:
 - Concrete state-of-the-art solutions and reference improvements
 - Best practices for wide-scale implementation
 - Blueprints for long-term strategies and implementation actions for all Danube ports
 - Recommendations, guidelines and manuals for support
 - Win – win situations between economic effectiveness and environmental sustainability

Project issues



- Project initiator/co-ordinator: Pro Danube - Association for the promotion of Danube waterway
- Lead partner: The Maritime Danube Ports Administration Galati / Romania
- Project partners: port authorities, terminal operators, port users, waterway authorities, energy efficiency agencies, centres for renewable energy, research institutes, NGO's, private terminal operators, reference groups from equipment industry, terminal operators, renewable energy community, etc.
- More than a project: Blueprint for a multi-annual Danube-wide implementation program
- Contact: projects@apdm.galati.ro; seitz@prodanube.eu; capatu@prodanube.eu